

WEB
↓
CAD

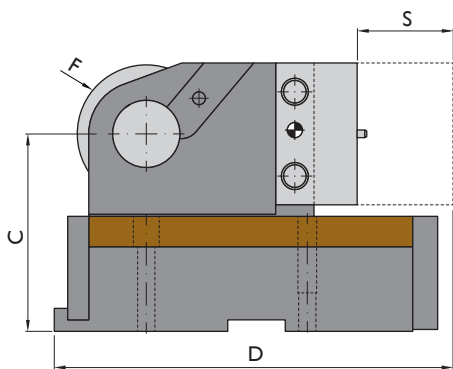

CAM DIAGRAM

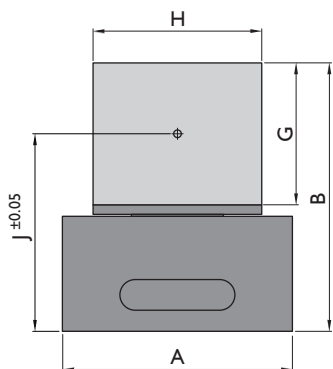
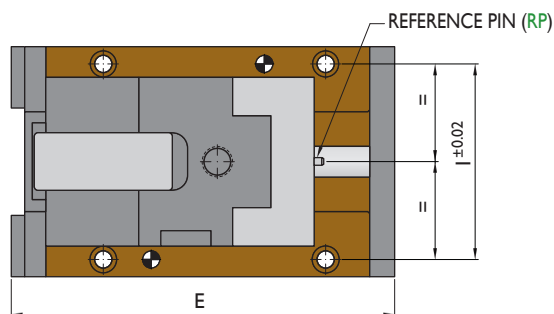
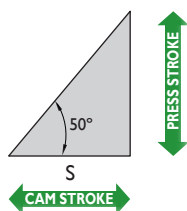
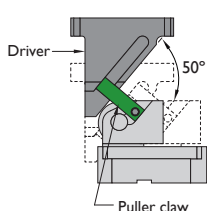

If placed in horizontal position:
1 mm. press stroke = 0.85. cam stroke

Ordering example: 4 x CRCS-03000-80 - RP (with reference pin)
4 x CRCS-03000-80 (without reference pin)



If a reference pin is required, mark it in the order as it is shown in the ordering example.

Maximum inclination angle

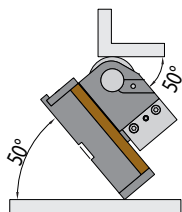
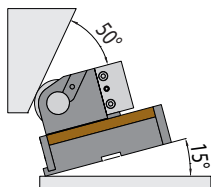

Optional accessories

DRIVER*

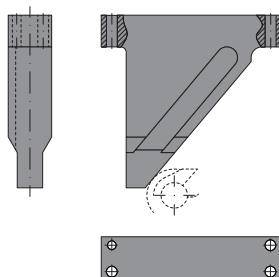

PULLER CLAW

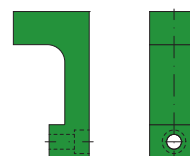

See dimensions on page 28.

Ordering example: CRCS-03000-52

Ordering example: CRCS-03000-C2

* Driver for installation angle 0°. For any other installation angle, contact with NITROGAS engineering.

Order No.			General Dimensions												Accessories ⁽¹⁾	
Model	Working Force daN	S mm	Weight kg	Spring Force daN	A mm	B mm	C mm	D mm	E mm	F mm	G mm	H mm	I mm	J mm	Driver	Puller Claw
CRCS 02000	22	3	180	75	85	63	103	115	23	50	50	63	63	CRCS-02000-51	CRCS-02000-C1	
CRCS 02000	35	3.7	190	75	85	63	137	136	23	50	50	63	63	CRCS-02000-52	CRCS-02000-C2	
CRCS 03000	50	10.7	450	100	117	86	208	200	31	63	68	82	86	CRCS-03000-51	CRCS-03000-C1	
CRCS 03000	80	11.1	450	100	117	86	238	230	31	63	68	82	86	CRCS-03000-52	CRCS-03000-C2	
CRCS 03000	100	16.9	540	100	117	110	258	260	31	63	68	82	86	CRCS-03000-53	CRCS-03000-C3	
CRCS 05000	50	15.4	450	120	140	103	208	200	36	74	88	102	103	CRCS-05000-51	CRCS-05000-C1	
CRCS 05000	80	17	450	120	140	103	238	230	36	74	88	102	103	CRCS-05000-52	CRCS-05000-C2	
CRCS 05000	100	18.3	540	120	140	103	258	260	36	74	88	102	103	CRCS-05000-53	CRCS-05000-C3	
CRCS 15000	50	28.8	910	170	165	120	216	220	45	92	132	150	120	CRCS-15000-51	CRCS-15000-C1	
CRCS 15000	80	29	910	170	165	120	246	250	45	92	132	150	120	CRCS-15000-52	CRCS-15000-C2	
CRCS 15000	100	29.8	710	170	165	120	266	270	45	92	132	150	120	CRCS-15000-53	CRCS-15000-C3	
CRCS 20000	50	61.8	1200	240	205	150	258	250	55	110	196	222	150	CRCS-20000-51	CRCS-20000-C1	
CRCS 20000	80	62.1	1200	240	205	150	288	280	55	110	196	222	150	CRCS-20000-52	CRCS-20000-C2	
CRCS 20000	100	65.4	1200	240	205	150	308	300	55	110	196	222	150	CRCS-20000-53	CRCS-20000-C3	

⁽¹⁾ For more information about accessories contact with NITROGAS engineering at engineering@nitrogas.com



More details about Roller Cam Units and spare parts on our website:

<http://www.nitrogas.com/es/CRCS.aspx>